

A combo platter of decimals, area, perimeter, and guacamole.

RUN A TACOTRUCK

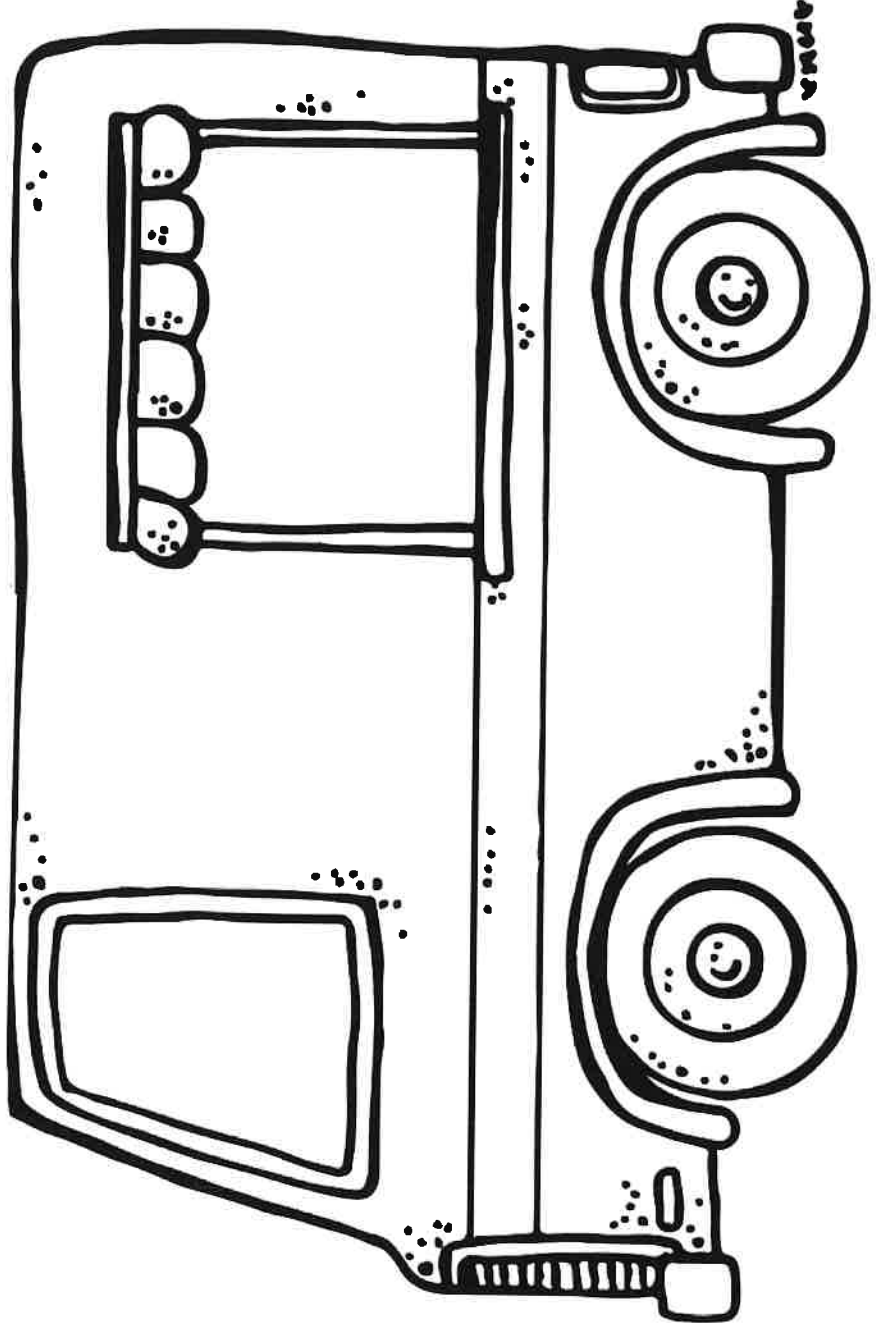

»»
name
»»

RUN A TACO TRUCK

Welcome to the food business! Well, actually the food truck business. Well, to be more accurate...the taco truck business.

That's right, you will be running a taco truck.

More and more food trucks are becoming high priorities in the eating world. Whether it's a lunch crowd or a spot by a concert, food trucks are in high demand. Plus, the food isn't just good...it's great.

For this project you will begin as a business start-up, move to creating the menu, and then create your very own taco truck. It's a combo platter of real-world math applications of decimals, money, area, perimeter, and more.

This project is divided in to **THREE** sections.

START - UP

This is where your business begins! You'll create a name, logo, and even do a little design work.

You'll also be asked to think about some obstacles you might face when running a business.

MENU

Nothing is more important than a quality meal. Now, you get to make all the decisions for the tacos.

Then you'll be taking orders from your classmates. Get ready to become a master taco truck chef.

FOOD TRUCK

For the final portion, you get to create your own taco truck.

That's right! You will completely design and create a three-dimensional truck. Make it the way you like it, then make some tacos.

taco truck

START-UP

List three ideas for a business name and then pick your favorite.

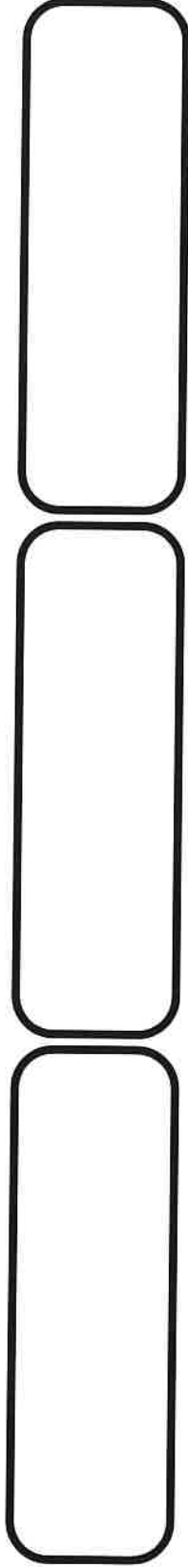

MY BUSINESS IS NAMED:

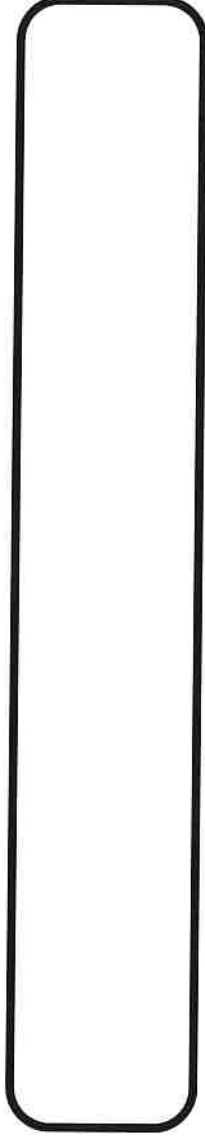

CREATE A LOGO

Brainstorm three logos for your business and draw them below. Pick the one you like the best.

REMEMBER: This is all about tacos, so think about a design that could include them in some way.

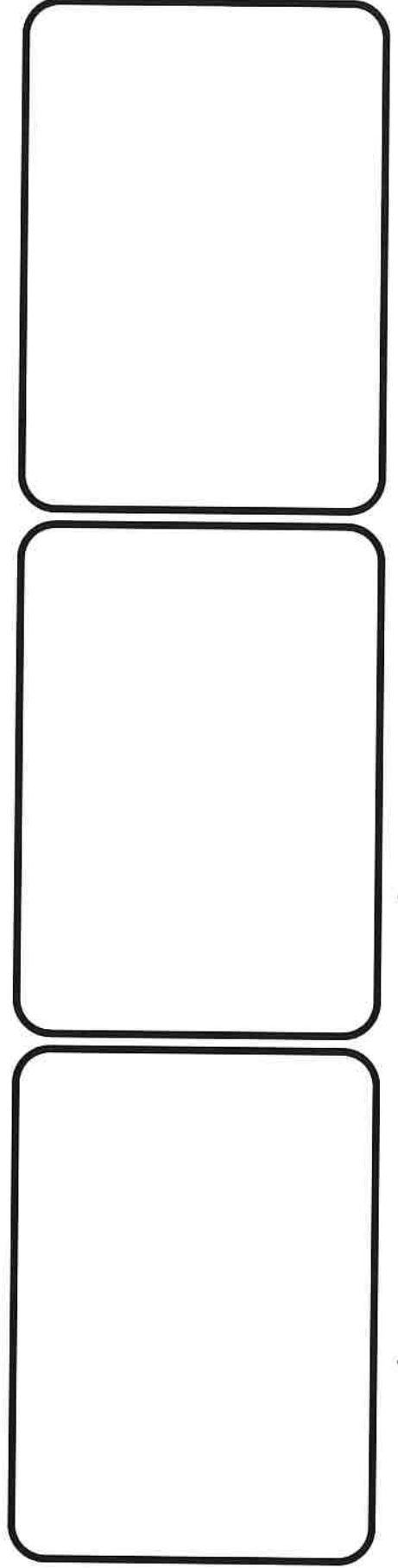

taco truck **START-UP**

Using your business name and logo, create three different versions of how you might like your truck to look.

When you design the trucks, think about using different colors or a color scheme that is eye-catching.

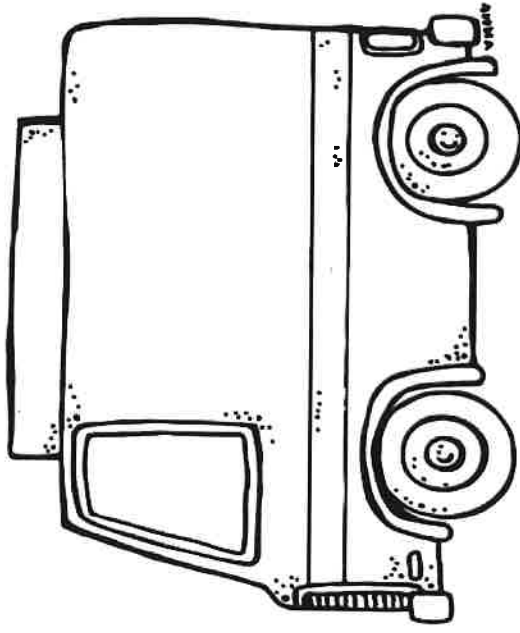
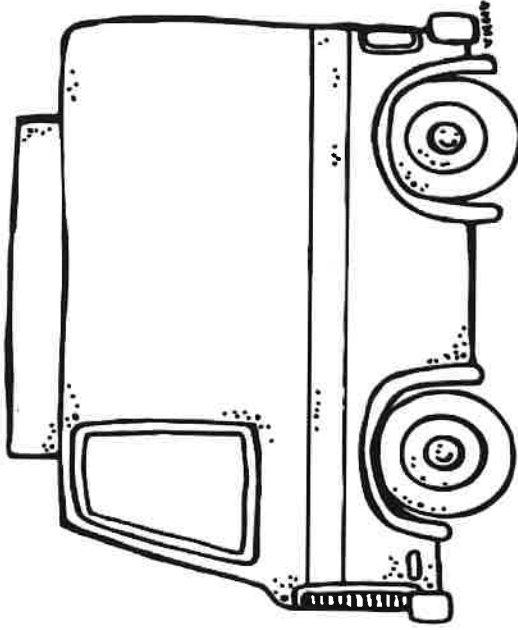
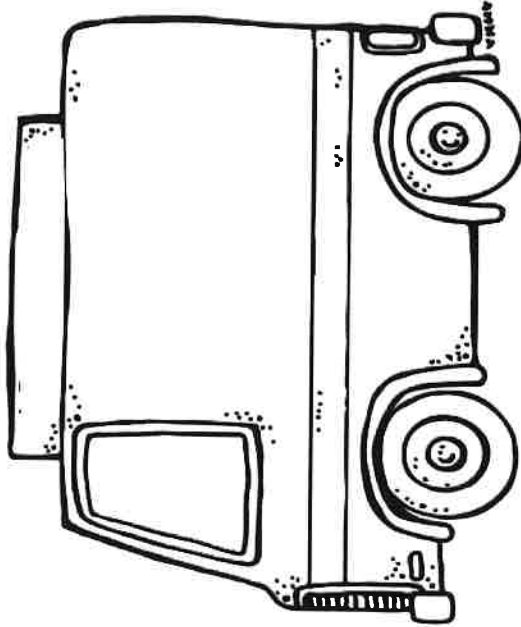

Which version did you like the best? Why?

Why are great designs and logos so important to businesses?

taco truck **START-UP**

Using your business name and logo, create three different versions of how you might like your taco truck to look.

When you design the trucks, think about using different colors or a color scheme that is eye-catching.

Which version did you like the best? Why?

Why are great designs and logos so important to businesses?

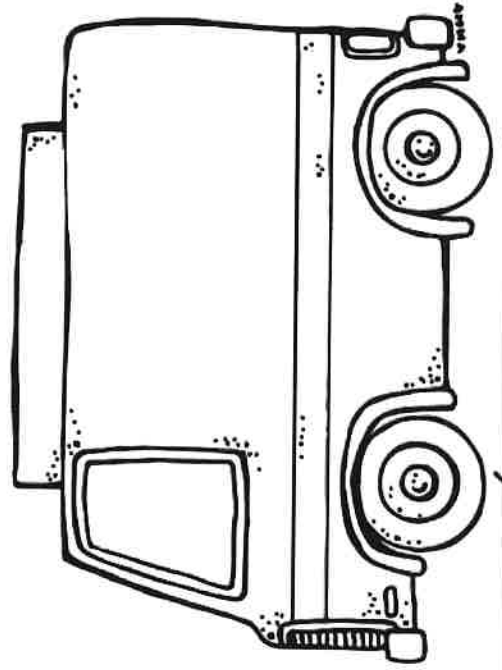
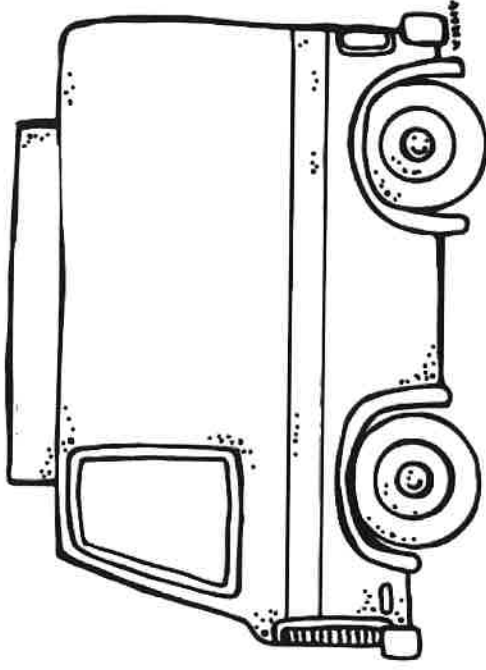
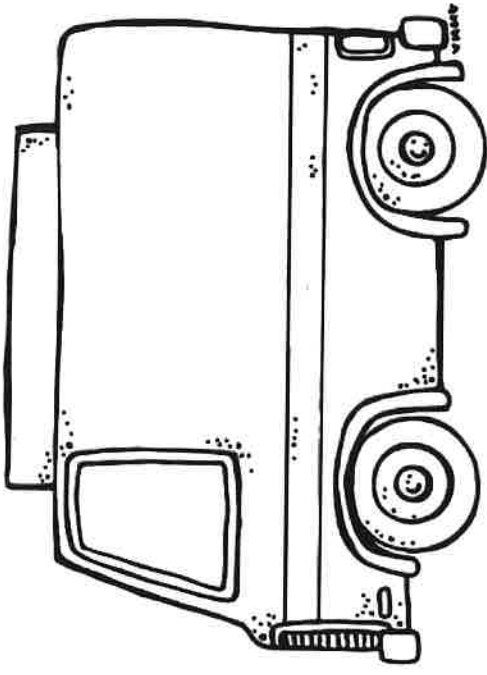

Think a little deeper about YOUR taco truck business, then answer the questions below.

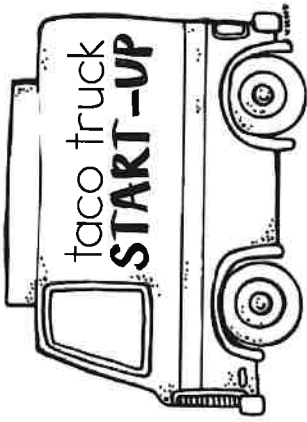

What will your slogan be?

How will your business be unique from other taco trucks? Why should customers come order from you?

Business Hours of Operation

Weekdays:

Weekends:

How will you advertise your business?

What problems could you run in to?
